

Adjustable Upper Ball Joint Installation Instructions

1. Inspect vehicle for loose or worn parts and odd tire wear patterns. Check tire pressure. Determine amount of camber/caster change needed.
2. Raise and support vehicle securely under lower control arms.
3. Remove wheel assembly. Remove cotter pin and nut from upper ball joint stud.
4. Remove upper ball joint from steering knuckle.
IMPORTANT- do not allow knuckles to pull out on axle shaft - inner CV joint disassembly may occur.
5. Install adjustable ball joint in upper control arm. Install lock nut. Snug nut to point where ball joint can just turn in control arm. **(See Fig. 1)**
6. Install ball joint stud into steering knuckle. Install nut and torque to 30-35 ft lbs. (40-48 NM).
7. Reinstall tire and wheel assembly. Recompensate alignment equipment. Recheck camber and caster readings. Proceed to step 9 - be sure to use alignment equipment manufacturer's recommended procedures.
8. Turn ball joint with Allen wrench to desired camber/caster settings. **(See Fig. 2)**
9. Raise vehicle using a suitable body lifting point to allow the control arms to drop. Hold ball joint with Allen wrench to prevent rotating and torque upper nut to 140-160 ft lbs. (190-217 NM).
10. Lower vehicle and verify proper camber and caster readings. Set toe to specifications and road test vehicle.

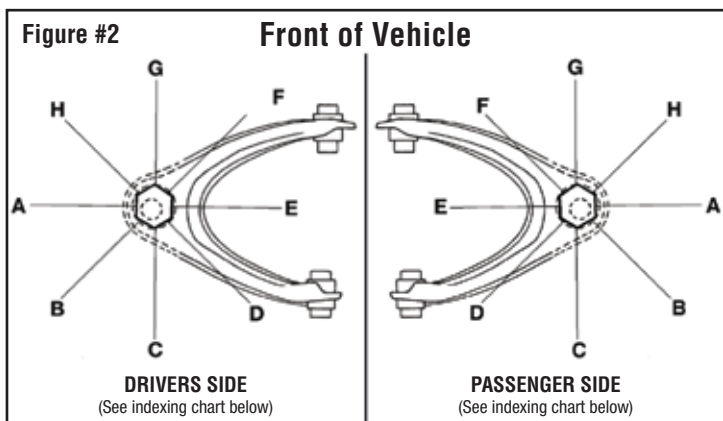
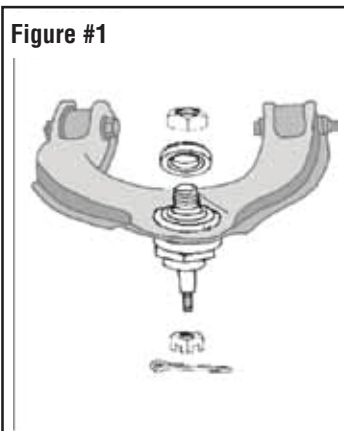

INDEXING CHART		
Referenced from position of offset stud		
Position	Camber Change	Caster Change
A	+	0
B	+	+
C	0	+
D	-	+
E	-	0
F	-	-
G	0	-
H	+	-